

# MOD:XEFT-04HS-EMRV-GB



## ENGLISH

## TECHNICAL DATA

01 POWER	3 kW
03 FREQUENCY	50 / 60 Hz
04 POWER SUPPLY CABLE TYPE	H07RN-F
05 EXTERNAL Ø OF POWER SUPPLY CABLE	10 mm
06 VOLTAGE / POWER CABLE SECTION / CURRENT	220-240 V~1PH+PE 3G x 1,5 mm <sup>2</sup> Circuit Breaker 16 A I1=13 A - I2= - I3= - In=
10 WATER PRESSURE	150-600 kPa
11 MAX FOOD LOAD	18 kg
13 WATER MAX CONSUMPTION	5 l/h @ 200 kPa
02 NOMINAL HEAT INPUT	2.7 kW
18 CAVITY DIMENSIONS ( W - D - H )	496x349x335 mm
20 IP PROTECTION CLASS	X4

## ITALIANO

01 POTENZA	3 kW
03 FREQUENZA	50 / 60 Hz
04 TIPO DI CAVO ALIMENTAZIONE	H07RN-F
05 Ø ESTERNO CAVO DI ALIMENTAZIONE	10 mm
06 TENSIONE / SEZIONE CAVI ALIMENTAZIONE / CORRENTE	220-240 V~1PH+PE 3G x 1,5 mm <sup>2</sup> Circuit Breaker 16 A I1=13 A - I2= - I3= - In=
10 PRESSIONE ACQUA	150-600 kPa
11 CARICA MAX CIBO	18 kg
13 CONSUMO MAX ACQUA	5 l/h @ 200 kPa
02 POTENZA TERMICA NOMINALE	2.7 kW
18 DIMENSIONI CAMERA COTTURA ( L - P - H )	496x349x335 mm
20 GRADO PROTEZIONE IP	X4

## FRANCAIS

01 PUISSANCE ELECTRIQUE	3 kW
03 FREQUENCE	50 / 60 Hz
04 TYPE DE CABLE D'ALIMENTATION	H07RN-F
05 Ø EXTERNE DU CABLE D'ALIMENTATION	10 mm
06 TENSION / SECTION CABLE D'ALIM.	220-240 V~1PH+PE 3G x 1,5 mm <sup>2</sup> Circuit Breaker 16 A I1=13 A - I2= - I3= - In=
10 PRESSION DE L'EAU	150-600 kPa
11 CHARGE MAXIMALE D'ALIMENT	18 kg
13 CONSOMMATION MAX DE L'EAU	5 l/h @ 200 kPa
02 DEBIT THERMIQUE NOMINAL	2.7 kW
18 DIMENSIONS CHAMBRE DE CUISSON ( L - P - A )	496x349x335 mm
20 INDICE DE PROTECTION IP	X4

## ESPAÑOL

01 POTENCIA	3 kW
03 FRECUENCIA	50 / 60 Hz
04 TIPO DE CABLE DE ALIMENTACION	H07RN-F
05 Ø CABLE EXTERNO DE ALIMENTACION	10 mm
06 TENSION / SECCION CABLES DE ALIMENTACION	220-240 V~1PH+PE 3G x 1,5 mm <sup>2</sup> Circuit Breaker 16 A I1=13 A - I2= - I3= - In=
10 PRESION AGUA	150-600 kPa
11 CARGA MAX. DE ALIMENTOS	18 kg
13 CONSUMO MAX DE AGUA	5 l/h @ 200 kPa
02 POTENCIA TERMICA NOMINAL	2.7 kW
18 DIMENSIONES CÁMARA DE COCCIÓN ( An - Pr - Al )	496x349x335 mm
20 GRADO DE PROTECCION IP	X4

## DEUTSCH

01 ELEKTRISCHE LEISTUNG	3 kW
03 FREQUENZ	50 / 60 Hz
04 ZULEITUNGSKABELTYP	H07RN-F
05 AUSSENDURCHMESSER DES VERSORGUNGSKABELS	10 mm
06 KABELQUERSCHNITT UND VERSORGUNGSSPANNUNG	220-240 V~1PH+PE 3G x 1,5 mm <sup>2</sup> Circuit Breaker 16 A I1=13 A - I2= - I3= - In=
10 WASSERDRUCK	150-600 kPa
11 MAX. SPEISENFASSUNGSVERMOGEN	18 kg
13 MAXIMUM WASSERVERBRAUCH	5 l/h @ 200 kPa
02 NOMINALE WARMELEISTUNG	2.7 kW
18 GRÖÖBE DES KOCHKAMMERS ( B - T - H )	496x349x335 mm
20 SCHTZART IP	X4

# MOD:XEFT-04HS-EMRV-GB



## ENGLISH - DRAWINGS

2	TERMINAL BOARD POWER SUPPLY
3	UNIPOTENTIAL TERMINAL
6	TECHNICAL DATA PLATE
7	SAFETY THERMOSTAT
8	3/4" THREAD WATER INLET
11	CAVITY DRAIN PIPE
12	HOT FUMES EXHAUST CHIMNEY
13	ACCESSORIES CONNECTION
27	COOLING AIR OUTLET

## ITALIANO - DISEGNI

2	MORSETTIERA ALIMENTAZIONE
3	MORSETTO EQUIPOTENZIALE
6	TARGHETTA DATI TECNICI
7	TERMOSTATO DI SICUREZZA
8	INGRESSO ACQUA 3/4"
11	SCARICO CAMERA DI COTTURA
12	USCITA FUMI CALDI
13	COLLEGAMENTO ACCESSORI
27	USCITA ARIA DI RAFFREDDAMENTO

## FRANCAIS - ENCOMBREMEN

2	BOITE A BORNES D'ALIMENTATION
3	SUPPORT BORNE EQUIPOTENTIELLE
6	PLAQUETTE SIGNALÉTIQUE
7	THERMOSTAT DE SÉCURITÉ
8	ARRIVÉ D'EAU FIÉLT 3/4"
11	SORTIE DE L'EAU RACCORD
12	SORTIE DES FUMÉES CHAUDES
13	JONCTION DES ACCESSOIRES
27	SORTIE D'EAU DE REFROIDISSEMENT

## ESPAÑOL - DISEÑOS

2	CAJA DE CONEXION
3	SEDE BORNE EQUIPOTENCIAL
6	TARJETA DE CARACTERISTICAS TECNICAS
7	TERMOSTATO DE SEGURIDAD
8	ENTRADA DE AGUA 3/4"
11	DESCARGA CAMARA DE COCCION
12	SALIDA HUMOS CALIENTES
13	CONEXION ACCESORIOS
27	SALIDA DEL AIRE DE ENFRIAMIENTO

## DEUTSCH - ZEICHNUNGEN

2	ZULEITUNGSKLEMMLEISTE
3	GLEICHPOTENTIELLE KLAMMER
6	TYPENSCHILD
7	SICHERHEITSTHERMOSTAT
8	WASSEREINZUG 3/4" GEWINDE
11	WASSERAUSLASS GEWINDE
12	ABZUGSHAUBE
13	ZUBEHÖRTEILENVERBINDUNG
27	KÜLLLUFTAUSTRITT

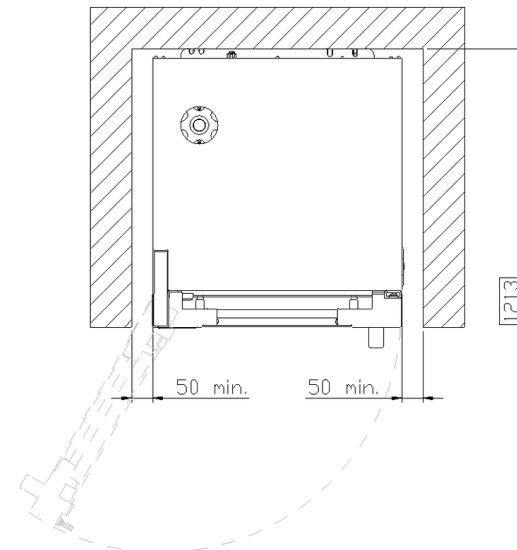
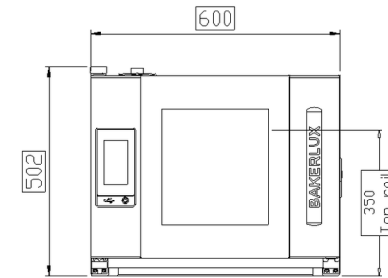
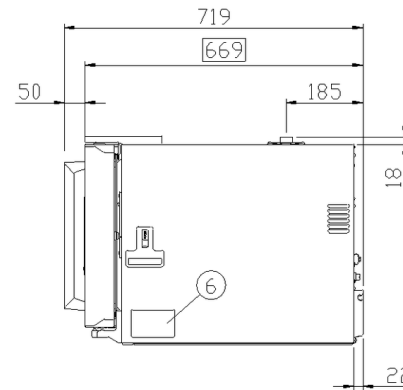
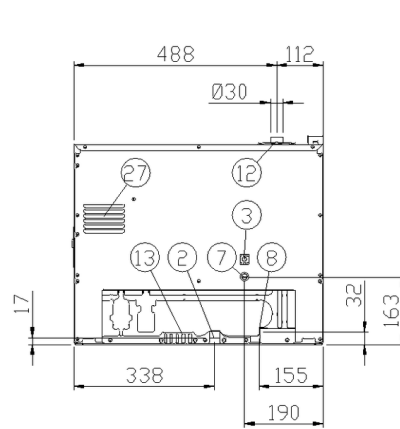

# MOD:XEFT-04HS-EMRV-GB

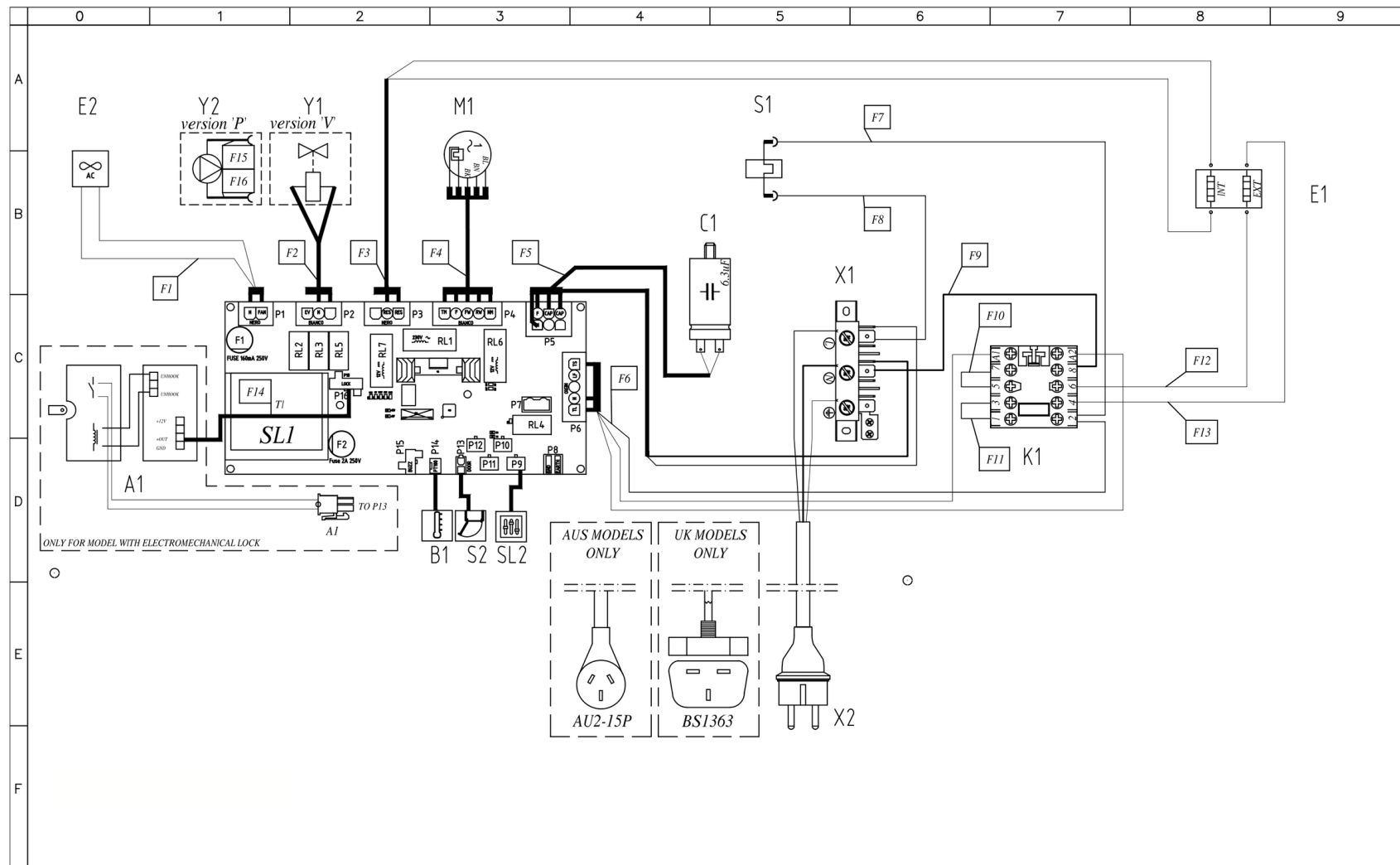

# MOD:XEFT-04HS-EMRV-GB



	0	1	2	3	4	5	6	7	8	9																																																																																																
A																																																																																																										
B																																																																																																										
C	<table border="1"> <thead> <tr> <th>Sigle</th> <th>ITALIANO</th> <th>ENGLISH</th> <th>FRANCAIS</th> <th>ESPAÑOL</th> <th>DEUTSCH</th> </tr> </thead> <tbody> <tr> <td>C1</td> <td>CONDENSATORE</td> <td>MOTOR CAPACITOR</td> <td>CONDENSATEUR</td> <td>CONDENSADOR</td> <td>KONDENSATOR</td> </tr> <tr> <td>K1</td> <td>TELERUTTORE</td> <td>CONTACTOR</td> <td>TELERUPTEUR</td> <td>TELERRUPTOR</td> <td>RELAIS</td> </tr> <tr> <td>SL1</td> <td>SCHEDA POTENZA</td> <td>POWER CARD</td> <td>CARTE DE PUISSANCE</td> <td>TARJETA POTENCIA</td> <td>POWERPLATINE</td> </tr> <tr> <td>X1</td> <td>MORSETTIERA</td> <td>CONTACTOR</td> <td>BORNIER</td> <td>CONECTOR</td> <td>KLEMMLEISTE</td> </tr> <tr> <td>X2</td> <td>CAVO ALIMENTAZIONE + SCHUKO</td> <td>POWER CORD + SCHUKO</td> <td>EPINIERE ET SCHUKO</td> <td>CABLE Y ENCHUFE SCHUKO</td> <td>KABEL UND SCHUKO-STECKER</td> </tr> <tr> <td>X3</td> <td>CAVO ALIMENTAZIONE + BS1363</td> <td>POWER CORD + BS1363</td> <td>EPINIERE ET BS1363</td> <td>CABLE Y ENCHUFE BS1363</td> <td>KABEL UND BS1363-STECKER</td> </tr> <tr> <td>B1</td> <td>SONDA CAMERA</td> <td>TEMPERATURE PROBE</td> <td>SONDE DE CHAMBRE</td> <td>SONDA CAMARA</td> <td>GARRAUMTEMPERATURFUHLER</td> </tr> <tr> <td>E1</td> <td>ELEMENTO RISCALDANTE</td> <td>HEATING ELEMENT</td> <td>ELEMENT DE CHAUFFAGE</td> <td>RESISTENCIA DE CALEFACCIÓN</td> <td>HEIZUNG</td> </tr> <tr> <td>E2</td> <td>VENTOLA RAFFREDDAMENTO 230V</td> <td>COOLING FAN 230V</td> <td>TURBINE DE REPRODISSEMENT 230V</td> <td>TURBINA DE REFRIGERACION 230V</td> <td>LÜFTER 230V</td> </tr> <tr> <td>M1</td> <td>MOTORE</td> <td>MOTOR</td> <td>MOTEUR</td> <td>MOTOR</td> <td>MOTOR</td> </tr> <tr> <td>S1</td> <td>TERMOSTATO SICUREZZA</td> <td>SAFETY THERMOSTAT</td> <td>THERMOSTAT DE SECURITE</td> <td>TERMOSTATO DE SEGURIDAD</td> <td>SICHERHEITS THERMOSTAT</td> </tr> <tr> <td>S2</td> <td>MICRO INTERRUTTORE PORTA</td> <td>DOOR MICROSWITCH</td> <td>MICROINTERRUPTEUR DE PORTE</td> <td>MICROINTERRUPTOR PUERTA</td> <td>TURKONTAKTSCHALTER</td> </tr> <tr> <td>SL2</td> <td>SCHEDA CONTROLLO</td> <td>CONTROL BOARD</td> <td>CARTE DE CONTROLE</td> <td>TARJETA DE CONTROL</td> <td>KONTROLL PLATINE</td> </tr> <tr> <td>Y1</td> <td>ELETTROVALVOLA ACQUA</td> <td>WATER SOLENOID VALVE</td> <td>ELECTROVANNE EAU</td> <td>ELECTROVALVULA</td> <td>ELEKTROVENTIL</td> </tr> <tr> <td>Y2</td> <td>POMPA</td> <td>PUMP</td> <td>POMPE</td> <td>BOMBA</td> <td>PUMPE</td> </tr> </tbody> </table>	Sigle	ITALIANO	ENGLISH	FRANCAIS	ESPAÑOL	DEUTSCH	C1	CONDENSATORE	MOTOR CAPACITOR	CONDENSATEUR	CONDENSADOR	KONDENSATOR	K1	TELERUTTORE	CONTACTOR	TELERUPTEUR	TELERRUPTOR	RELAIS	SL1	SCHEDA POTENZA	POWER CARD	CARTE DE PUISSANCE	TARJETA POTENCIA	POWERPLATINE	X1	MORSETTIERA	CONTACTOR	BORNIER	CONECTOR	KLEMMLEISTE	X2	CAVO ALIMENTAZIONE + SCHUKO	POWER CORD + SCHUKO	EPINIERE ET SCHUKO	CABLE Y ENCHUFE SCHUKO	KABEL UND SCHUKO-STECKER	X3	CAVO ALIMENTAZIONE + BS1363	POWER CORD + BS1363	EPINIERE ET BS1363	CABLE Y ENCHUFE BS1363	KABEL UND BS1363-STECKER	B1	SONDA CAMERA	TEMPERATURE PROBE	SONDE DE CHAMBRE	SONDA CAMARA	GARRAUMTEMPERATURFUHLER	E1	ELEMENTO RISCALDANTE	HEATING ELEMENT	ELEMENT DE CHAUFFAGE	RESISTENCIA DE CALEFACCIÓN	HEIZUNG	E2	VENTOLA RAFFREDDAMENTO 230V	COOLING FAN 230V	TURBINE DE REPRODISSEMENT 230V	TURBINA DE REFRIGERACION 230V	LÜFTER 230V	M1	MOTORE	MOTOR	MOTEUR	MOTOR	MOTOR	S1	TERMOSTATO SICUREZZA	SAFETY THERMOSTAT	THERMOSTAT DE SECURITE	TERMOSTATO DE SEGURIDAD	SICHERHEITS THERMOSTAT	S2	MICRO INTERRUTTORE PORTA	DOOR MICROSWITCH	MICROINTERRUPTEUR DE PORTE	MICROINTERRUPTOR PUERTA	TURKONTAKTSCHALTER	SL2	SCHEDA CONTROLLO	CONTROL BOARD	CARTE DE CONTROLE	TARJETA DE CONTROL	KONTROLL PLATINE	Y1	ELETTROVALVOLA ACQUA	WATER SOLENOID VALVE	ELECTROVANNE EAU	ELECTROVALVULA	ELEKTROVENTIL	Y2	POMPA	PUMP	POMPE	BOMBA	PUMPE									
Sigle	ITALIANO	ENGLISH	FRANCAIS	ESPAÑOL	DEUTSCH																																																																																																					
C1	CONDENSATORE	MOTOR CAPACITOR	CONDENSATEUR	CONDENSADOR	KONDENSATOR																																																																																																					
K1	TELERUTTORE	CONTACTOR	TELERUPTEUR	TELERRUPTOR	RELAIS																																																																																																					
SL1	SCHEDA POTENZA	POWER CARD	CARTE DE PUISSANCE	TARJETA POTENCIA	POWERPLATINE																																																																																																					
X1	MORSETTIERA	CONTACTOR	BORNIER	CONECTOR	KLEMMLEISTE																																																																																																					
X2	CAVO ALIMENTAZIONE + SCHUKO	POWER CORD + SCHUKO	EPINIERE ET SCHUKO	CABLE Y ENCHUFE SCHUKO	KABEL UND SCHUKO-STECKER																																																																																																					
X3	CAVO ALIMENTAZIONE + BS1363	POWER CORD + BS1363	EPINIERE ET BS1363	CABLE Y ENCHUFE BS1363	KABEL UND BS1363-STECKER																																																																																																					
B1	SONDA CAMERA	TEMPERATURE PROBE	SONDE DE CHAMBRE	SONDA CAMARA	GARRAUMTEMPERATURFUHLER																																																																																																					
E1	ELEMENTO RISCALDANTE	HEATING ELEMENT	ELEMENT DE CHAUFFAGE	RESISTENCIA DE CALEFACCIÓN	HEIZUNG																																																																																																					
E2	VENTOLA RAFFREDDAMENTO 230V	COOLING FAN 230V	TURBINE DE REPRODISSEMENT 230V	TURBINA DE REFRIGERACION 230V	LÜFTER 230V																																																																																																					
M1	MOTORE	MOTOR	MOTEUR	MOTOR	MOTOR																																																																																																					
S1	TERMOSTATO SICUREZZA	SAFETY THERMOSTAT	THERMOSTAT DE SECURITE	TERMOSTATO DE SEGURIDAD	SICHERHEITS THERMOSTAT																																																																																																					
S2	MICRO INTERRUTTORE PORTA	DOOR MICROSWITCH	MICROINTERRUPTEUR DE PORTE	MICROINTERRUPTOR PUERTA	TURKONTAKTSCHALTER																																																																																																					
SL2	SCHEDA CONTROLLO	CONTROL BOARD	CARTE DE CONTROLE	TARJETA DE CONTROL	KONTROLL PLATINE																																																																																																					
Y1	ELETTROVALVOLA ACQUA	WATER SOLENOID VALVE	ELECTROVANNE EAU	ELECTROVALVULA	ELEKTROVENTIL																																																																																																					
Y2	POMPA	PUMP	POMPE	BOMBA	PUMPE																																																																																																					
D																																																																																																										
E																																																																																																										
F																																																																																																										