

MOD:XEFT-03EU-EGDN-GB



ENGLISH

TECHNICAL DATA

01 POWER	3 kW
03 FREQUENCY	50 / 60 Hz
04 POWER SUPPLY CABLE TYPE	H07RN-F
05 EXTERNAL Ø OF POWER SUPPLY CABLE	10 mm
06 VOLTAGE / POWER CABLE SECTION / CURRENT	220-240 V~1PH+PE 3G x 1,5 mm ² Circuit Breaker 16 A I1=13 A - I2= - I3= - In=
10 WATER PRESSURE	15 kg
11 MAX FOOD LOAD	@ 200 kPa
13 WATER MAX CONSUMPTION	2.7 kW
02 NOMINAL HEAT INPUT	696x441x260 mm
18 CAVITY DIMENSIONS (W - D - H)	X4
20 IP PROTECTION CLASS	

ITALIANO

01 POTENZA	3 kW
03 FREQUENZA	50 / 60 Hz
04 TIPO DI CAVO ALIMENTAZIONE	H07RN-F
05 Ø ESTERNO CAVO DI ALIMENTAZIONE	10 mm
06 TENSIONE / SEZIONE CAVI ALIMENTAZIONE / CORRENTE	220-240 V~1PH+PE 3G x 1,5 mm ² Circuit Breaker 16 A I1=13 A - I2= - I3= - In=
10 PRESSIONE ACQUA	15 kg
11 CARICA MAX CIBO	@ 200 kPa
13 CONSUMO MAX ACQUA	2.7 kW
02 POTENZA TERMICA NOMINALE	696x441x260 mm
18 DIMENSIONI CAMERA COTTURA (L - P - H)	X4
20 GRADO PROTEZIONE IP	

FRANCAIS

01 PUISSANCE ELECTRIQUE	3 kW
03 FREQUENCE	50 / 60 Hz
04 TYPE DE CABLE D'ALIMENTATION	H07RN-F
05 Ø EXTERNE DU CABLE D'ALIMENTATION	10 mm
06 TENSION / SECTION CABLE D'ALIM.	220-240 V~1PH+PE 3G x 1,5 mm ² Circuit Breaker 16 A I1=13 A - I2= - I3= - In=
10 PRESSION DE L'EAU	15 kg
11 CHARGE MAXIMALE D'ALIMENT	@ 200 kPa
13 CONSOMMATION MAX DE L'EAU	2.7 kW
02 DEBIT THERMIQUE NOMINAL	696x441x260 mm
18 DIMENSIONS CHAMBRE DE CUISSON (L - P - A)	X4
20 INDICE DE PROTECTION IP	

ESPAÑOL

01 POTENCIA	3 kW
03 FRECUENCIA	50 / 60 Hz
04 TIPO DE CABLE DE ALIMENTACION	H07RN-F
05 Ø CABLE EXTERNO DE ALIMENTACION	10 mm
06 TENSION / SECCION CABLES DE ALIMENTACION	220-240 V~1PH+PE 3G x 1,5 mm ² Circuit Breaker 16 A I1=13 A - I2= - I3= - In=
10 PRESION AGUA	15 kg
11 CARGA MAX. DE ALIMENTOS	@ 200 kPa
13 CONSUMO MAX DE AGUA	2.7 kW
02 POTENCIA TERMICA NOMINAL	696x441x260 mm
18 DIMENSIONES CÁMARA DE COCCIÓN (An - Pr - Al)	X4
20 GRADO DE PROTECCION IP	

DEUTSCH

01 ELEKTRISCHE LEISTUNG	3 kW
03 FREQUENZ	50 / 60 Hz
04 ZULEITUNGSKABELTYP	H07RN-F
05 AUSSENDURCHMESSER DES VERSORGUNGSKABELS	10 mm
06 KABELQUERSCHNITT UND VERSORGUNGSSPANNUNG	220-240 V~1PH+PE 3G x 1,5 mm ² Circuit Breaker 16 A I1=13 A - I2= - I3= - In=
10 WASSERDRUCK	15 kg
11 MAX. SPEISENFASSUNGSVERMOGEN	@ 200 kPa
13 MAXIMUM WASSERVERBRAUCH	2.7 kW
02 NOMINALE WARMELEISTUNG	696x441x260 mm
18 GRÖÖBE DES KOCHKAMMERS (B - T - H)	X4
20 SCHTZART IP	

MOD:XEFT-03EU-EGDN-GB



ENGLISH - DRAWINGS	
2	TERMINAL BOARD POWER SUPPLY
3	UNIPOTENTIAL TERMINAL
6	TECHNICAL DATA PLATE
7	SAFETY THERMOSTAT
8	3/4" THREAD WATER INLET
11	CAVITY DRAIN PIPE
12	HOT FUMES EXHAUST CHIMNEY
13	ACCESSORIES CONNECTION
27	COOLING AIR OUTLET

ITALIANO - DISEGNI	
2	MORSETTIERA ALIMENTAZIONE
3	MORSETTO EQUIPOTENZIALE
6	TARGHETTA DATI TECNICI
7	TERMOSTATO DI SICUREZZA
8	INGRESSO ACQUA 3/4"
11	SCARICO CAMERA DI COTTURA
12	USCITA FUMI CALDI
13	COLLEGAMENTO ACCESSORI
27	USCITA ARIA DI RAFFREDDAMENTO

FRANCAIS - ENCOMBREMEN	
2	BOITE A BORNES D'ALIMENTATION
3	SUPPORT BORNE EQUIPOTENTIELLE
6	PLAQUETTE SIGNALTIQUE
7	THERMOSTAT DE SECURITE
8	ARRIVE' D'EAU FIELT 3/4"
11	SORTIE DE L'EAU RACCORD
12	SORTIE DES FUMEEES CHAUDES
13	JONCTION DES ACCESSOIRES
27	SORTIE D'EAU DE REFROIDISSEMENT

ESPAÑOL - DISEÑOS	
2	CAJA DE CONEXION
3	SEDE BORNE EQUIPOTENCIAL
6	TARJETA DE CARACTERISTICAS TECNICAS
7	TERMOSTATO DE SEGURIDAD
8	ENTRADA DE AGUA 3/4"
11	DESCARGA CAMARA DE COCCION
12	SALIDA HUMOS CALIENTES
13	CONEXION ACCESORIOS
27	SALIDA DEL AIRE DE ENFRIAMIENTO

DEUTSCH - ZEICHNUNGEN	
2	ZULEITUNGSKLEMMLEISTE
3	GLEICHPOTENTIELLE KLAMMER
6	TYPENSCHILD
7	SICHERHEITSTHERMOSTAT
8	WASSEREINZUG 3/4" GEWINDE
11	WASSERAUSLASS GEWINDE
12	ABZUGSHAUBE
13	ZUBEHÖRTEILENVERBINDUNG
27	KÜLLLUFTAUSTRITT

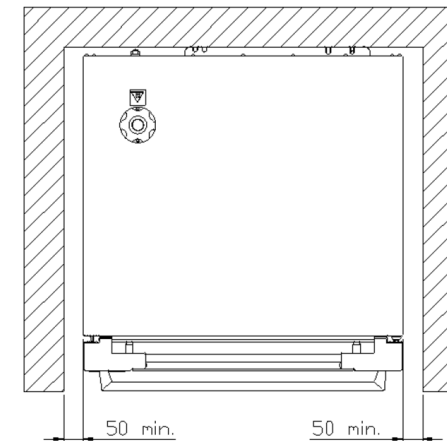
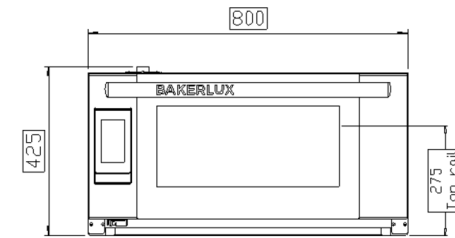
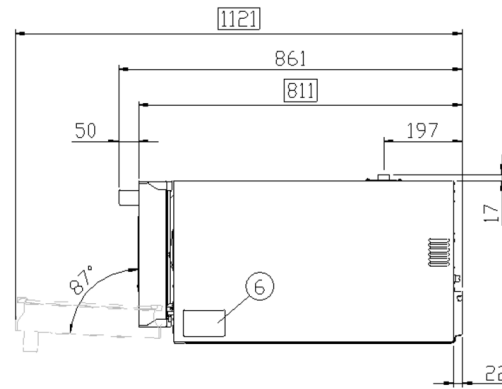
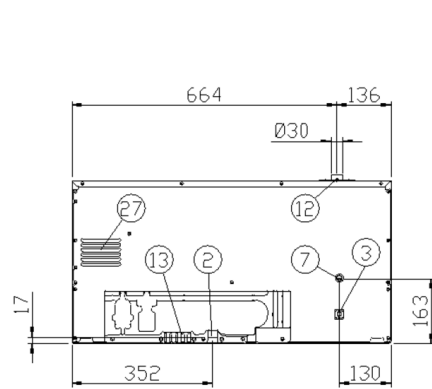

MOD:XEFT-03EU-EGDN-GB



	0	1	2	3	4	5	6	7	8	9
A										
B										
C										
D										
E										
F										

Q Sigle	ITALIANO	ENGLISH	FRANCAIS	ESPAÑOL	DEUTSCH
B1	SONDA CAMERA	TEMPERATURE PROBE	SONDE DE CHAMBRE	SONDA CAMARA	GARRAUMTEMPERATURFUHLER
C1	CONDENSATORE	MOTOR CAPACITOR	CONDENSATEUR	CONDENSADOR	KONDENSATOR
K1	TELERUTTORE	CONTACTOR	TELERUPTEUR	TELERRUPTOR	RELAIS
S1	MICRO INTERRUPTORE PORTA	DOOR MICROSWITCH	MICROINTERRUPTEUR DE PORTE	MICROINTERRUPTOR PUERTA	TURKONTAKTSCHALTER
SL3	SCHEDA POTENZA	POWER CARD	CARTE DE PUISSANCE	TARJETA POTENCIA	POWERPLATINE
X2	MORSETTIERA	CONTACTOR	BORNIER	CONECTOR	KLEMMLEISTE
X3	CAVO ALIMENTAZIONE + BS1363	POWER CORD + BS1363	E PINIERE ET BS1363	CABLE Y ENCHUFE BS1363	KABEL UND BS1363-STECKER
X4	CAVO ALIMENTAZIONE + SCHUKO	POWER CORD + SCHUKO	E PINIERE ET SCHUKO	CABLE Y ENCHUFE SCHUKO	KABEL UND SCHUKO-STECKER
E1	ELEMENTO RISCALDANTE	HEATING ELEMENT	ELEMENT DE CHAUFFAGE	RESISTENCIA DE CALEFACCIÓN	HEIZUNG
E2	VENTOLA RAFFREDDAMENTO 230V	COOLING FAN 230V	TURBINE DE REFROIDISSEMENT 230V	TURBINA DE REFRIGERACION 230V	LÜFTER 230V
M1	MOTORE	MOTOR	MOTEUR	MOTOR	MOTOR
S1	TERMOSTATO SICUREZZA	SAFETY THERMOSTAT	THERMOSTAT DE SECURITE	TERMOSTATO DE SEGURIDAD	SICHERHEITS THERMOSTAT
SL2	SCHEDA CONTROLLO	CONTROL BOARD	CARTE DE CONTROLE	TARJETA DE CONTROL	KONTROLL PLATINE